

EV CARGO VAN / BUS

Operators Guide



Document	Version	Date	Prepared	Comments
HB-BCI-VS-0043-24	1.0	Sept/2024	D.D	5.9 mtr vehicle

All rights reserved by Bus & Coach International Pty Ltd

Note: The content of this Operators Guide is to provide as much relevant information to the operators as possible. It may contain information on factory optional equipment, which may or may not be included in your vehicle.

Welcome to BCI

EV Cargo Van / Bus operators guide.

Congratulations on choosing a BCI vehicle.

The more familiar you are with your vehicle, the easier it will be to operate and enjoy. We offer the following advice:

Please read and understand the operator's guide for your vehicle. It contains essential information on how to operate and maximise the benefits of your advanced BCI Electric Vehicle (EV).

Every attempt has been made to ensure the information contained in this booklet is correct at the time of printing.

We wish you safe and pleasant journeys.

Table of Contents

1.0 Using this guide.....	5
2.0 Vehicle information	6
2.1 Vehicle identification number	7
3.0 Vehicle access	7
3.1 Key access	7
3.2 Ignition key	8
3.3 Sliding passenger/ parcel doors	8
3.4 Manual sliding passenger/ parcel door.....	8
3.5 Automatic sliding passenger door (bus)	8
4.0 Daily inspections	9
4.2 Pre-start inspection / internal cabin area	9
4.3 Pre-departure inspection / driver’s area	10
5.0 Driver’s area	11
5.1 Dash instrumentation.....	12
5.2 General warning lights (section 1).....	12
5.3 Speedometer warning lights (section 2)	13
5.4 Information screen (section 3).....	13
5.5 Battery stage of charge indicator (SOC) (section 4).	14
6.0 Operation	14
6.1 Lighting and turning stalk.	14
6.2 Wiper and washer stalk.....	14
6.3 Central switches	15
6.4 Driver’s seat.....	15
6.5 Gear selector	16
6.6 Steering.....	16
6.7 Braking system.....	16
6.8 Park brake (EPB).....	16
6.8.1 Hill Start Assist (HHC).....	17
6.8.2 Emergency Park brake release.....	17
6.8.3 Emergency braking function.	17
6.9 Electronic stability system (ESC)	17
7.0 Air conditioning and heating system	18

8.0 Multimedia	18
9.0 Passenger security	19
9.1 Seatbelt.....	19
9.2 Air bag.....	19
10.0 Charging point.....	20
10.1 Charging.....	20
10.2 High-voltage (HV) Batteries	21
11.00 Battery Isolation	22
11.1 Flat Batteries.....	22
12.0 Emergency shutdown Procedure	23
13.0 Start/Stop	23
14.0 Park assist	24
14.1 Reverse camera	24
15.0 Technical data.....	24
15.1 Specifications of the drive motor	24
15.2 Lubricants.....	24
15.3 Tyre size / inflation pressures	25
15.4 Wheel alignment specifications.....	25
16.0 Towing	25
17.0 Spare tyres.....	26

1.0 Using this guide

This guide is designed to help vehicle operators understand the **EV Cargo Van / Bus** product. Operators must strictly adhere to all local laws and regulations regarding the vehicle's operation.

Please operate the vehicle with care and attention. BCI will not be responsible for any loss caused by improper use of the product.

This document contains essential safety messages intended to prevent potential personal injuries. It is crucial to follow all the safety messages provided here to avoid injuries or fatalities. Pay particular attention to the following symbols and layouts.



WARNING

Indicates an imminent dangerous situation which, if not avoided, could result in death or serious injury.



HAZARD

Indicates an imminent hazardous situation which, if not avoided, could result in death or serious injury



DANGER

Indicates an imminent hazardous situation which, if not avoided, could result in death or serious injury



INFORMATION

Additional information which is important but not threatening to life and/or systems.

2.0 Vehicle information

BCI is a leading vehicle manufacturer striving for excellence and continues improvement throughout its range of vehicles.

The key features of this **BCI EV Cargo Van / Bus** includes:

- Permanent synchronised magnet drive.
- 120kW maximum power.
- 1200Nm of Torque.
- Zero emissions / full electric operation.
- Rear mounted drive motor.
- Battery capacity 105kW (3 x 35kW batteries)
- Battery Range 250 to 300kms
- Length (A) 5915 mm.
- Width (B) 2040 mm.
- Height (C) 2632 mm.
- Wheelbase (D) 3665 mm.
- Front overhang (E) 1014 mm
- Rear overhang (F) 1236mm

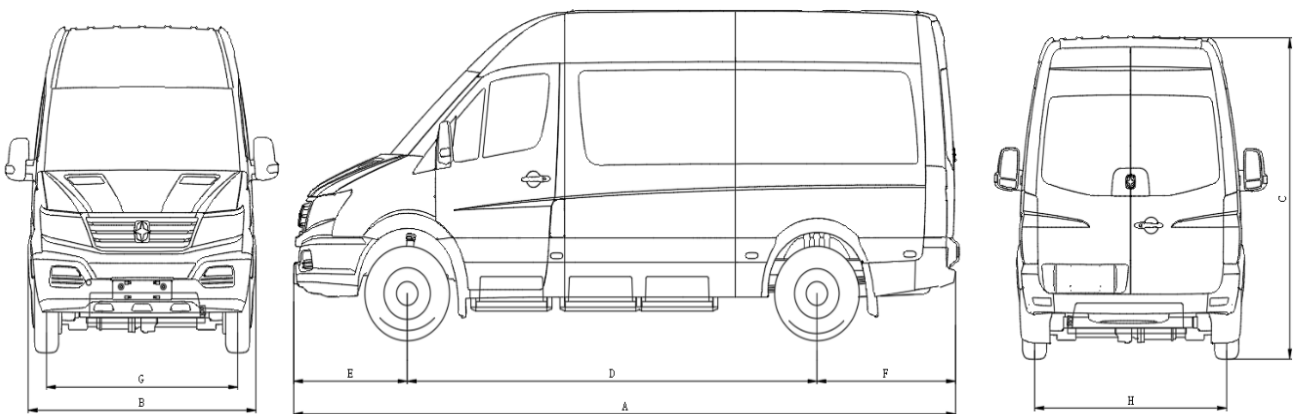

2.1 Vehicle identification number



WARNING

Never leave anyone unattended in a vehicle, especially children or animals. Prolonged exposure to extreme temperatures, whether hot or cold, can lead to serious injury or even death.

Vehicle identification number (VIN) is located in two places:

1. Behind the right-hand front tyre on chassis frame.
2. Inside the driver's door frame.



3.0 Vehicle access



INFORMATION

The key remote is electronically coded to each vehicle individually. If a replacement is needed, a specific procedure must be carried out by an authorized BCI dealer.

3.1 Key access

- ① to lock.
- ② to unlock.
- ③ to locate vehicle.
- ④ manual key.

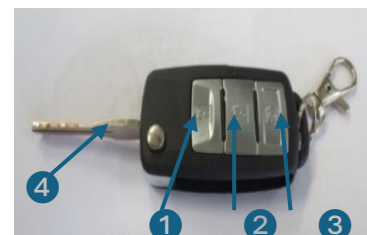

Turn signals will flash 3 times to confirm vehicle is locked. They will flash one to confirm doors are unlocked.

This vehicle is equipped with an anti-theft system that activates automatically when the doors are locked. A yellow warning light on the dashboard indicates the system is armed. If the light is flashing it has detected a fault.

Contact an authorised BCI dealer for assistance.

Locking / unlocking doors can be performed manually using the manual key (4).

To lock, rotate the key in clockwise direction. To unlock, rotate in a counterclockwise direction.



INFORMATION

Once the vehicle exceeds 15km/h all doors will automatically lock. The doors can only be unlocked using the driver's side door switch

3.2 Ignition key



INFORMATION

Never remove the ignition key when the vehicle is moving. The steering lock will then prevent it from steering.



There are 4 positions within the ignition key:

OFF	OFF. The ignition is turned off. Only point that the key can be inserted or removed.
ACC	Accessories, one click clockwise. Unlocks steering column and applies power to accessories such as radio.
ON	On, two clicks clockwise. Turns on ignition and activates all instruments and circuits.
START	Start, full turn clockwise and release, the key will automatically return to ON position.



INFORMATION

Avoid leaving the key in the **ON** position for extended periods of time when not driving, it will drain the battery.

3.3 Sliding passenger/ parcel doors

BCI's EV Cargo Van / Bus comes with two door options, manual and automatic versions.

3.4 Manual sliding passenger/ parcel door

To open the door from the outside, pull the external handle out and slide it rearward until you hear a positive click, indicating the door is fully open. To close the door, pull it forward and accelerate until it shuts securely into position.

To open the door from inside. Pull the handle (1) up whilst pulling rearward on the handle (2) until you hear a positive click, indicating the door is fully open.

To close the door, pull it forward and accelerate until it shuts securely into position.

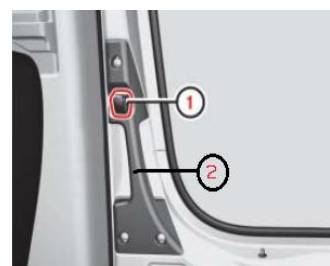

3.5 Automatic sliding passenger door (bus)

Using the dash mounted switch.

1. Press the down arrow and door will open and step light will turn on.
2. Press the up arrow and door will close and step light will turn off.





INFORMATION

An electrically operated sidestep will extend with the door opening and retract with the door closing.

4.0 Daily inspections



DANGER

Indicates an imminent hazardous situation which, if not avoided, could result in death or serious injury

Pre-start inspections are required prior to first departure of each shift.

Complete the pre-start daily vehicle inspection checklist. Pre-start inspection / external

Carry out external visual inspections of the vehicle examining its outer components to ensure they are in good condition and functioning properly.

External inspections		
1	Check charging lead is disconnected and properly stored.	
2	Check for loose or damaged panels.	
3	Check for damaged or flat tyres.	
4	Check for damage to any glass / including mirrors.	
5	Check for any visual fluid leaks.	
6	Lift bonnet and check wiper fluid level.	
7	Check security of wiper arms and blades.	
8	Check operation of all lights.	
9	Check and ensure all doors are operating correctly.	

4.2 Pre-start inspection / internal cabin area

Carry out visual inspection of the internal cabin area to ensure it ready to accept passengers.

Internal inspection		
1	Check general cleanliness of passenger area as well as for any loose items.	
2	Check seat belts and seat attachment for security and damage.	
3	Check fire extinguisher is attached and within date.	
4	Emergency hammers present	

4.3 Pre-departure inspection / driver's area

Inspection conducted from the driver's position prior to departure.

Pre-departure inspection		
1	Check driver's seat and seat belt for safety and condition.	
2	Gear selector is in NEUTRAL (N).	
3	Ignition switch ON.	
4	Audible fire suppression message received and heard (if applicable).	
5	Check instrumentation for any warning lights / alarms or faults.	
6	2-way radio on and volume set.	
7	Check internal light operates / including tell-tale on the dash area.	
8	Check operation of air conditioning system.	
9	Ensure minimum battery charge required to complete trip.	
10	Drive forward, apply brakes – check for smooth, controlled motions.	

5.0 Driver's area

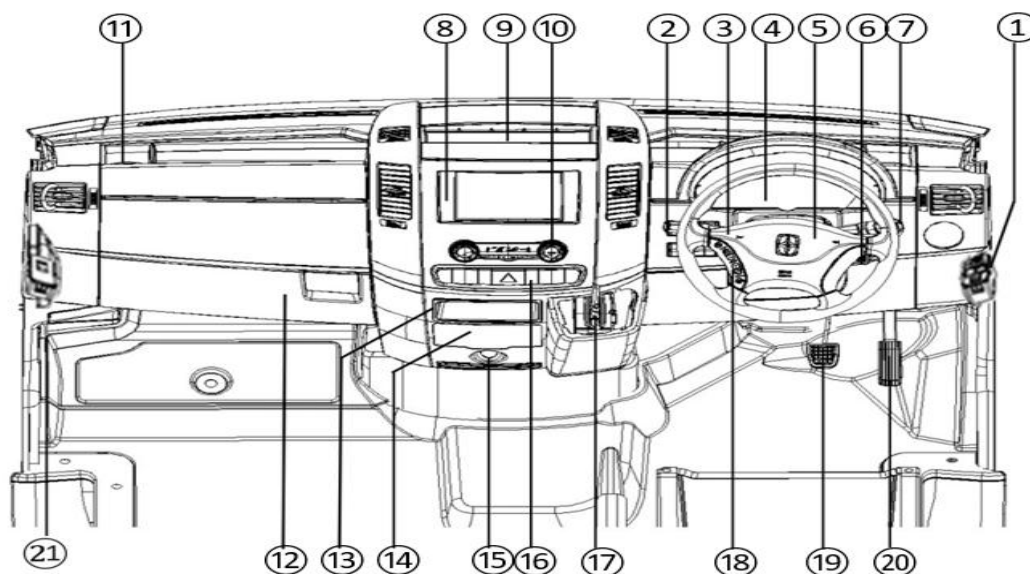

①	Driver's mirror controls.	②	Light / indicator combination switch.
③	Horn button.	④	Instrument cluster.
⑤	Driver's airbag.	⑥	Ignition key.
⑦	Wiper combination switch.	⑧	Entertainment system.
⑨	Centre storage compartment.	⑩	Air Conditioning system
⑪	Cup holder.	⑫	Glove box.
⑬	Lower storage compartment.	⑭	Ashtray.
⑮	12 Volts power position.	⑯	Central buttons and controls. (section 6.3 pg. 15)
⑰	Gear selector.	⑱	Multimedia control panels.
⑲	Brake pedal.	⑳	Accelerator pedal
㉑	Bonnet release		

5.1 Dash instrumentation

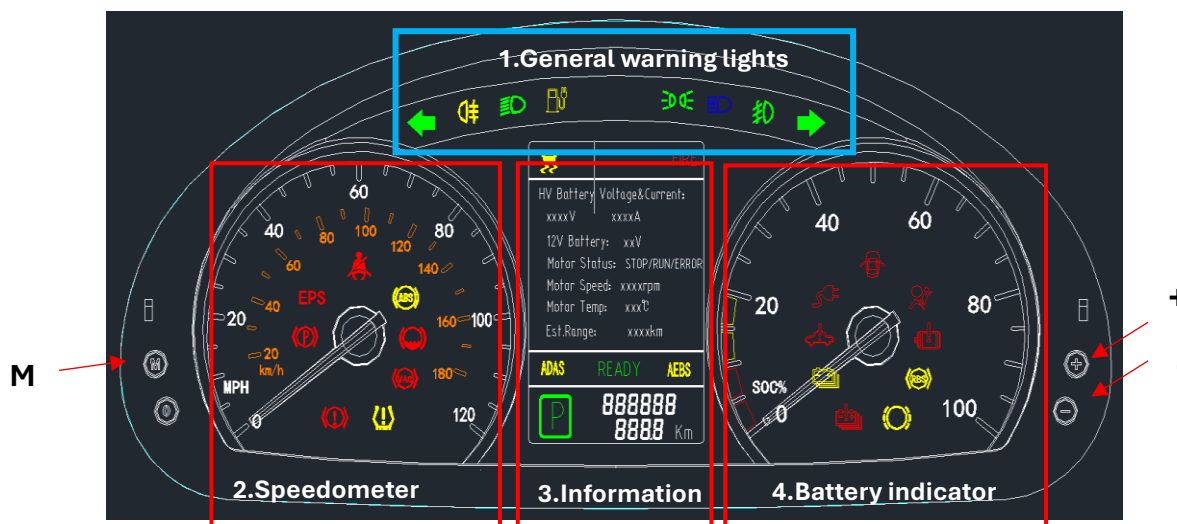

INFORMATION

If the battery state of charge (SOC) enters the red zone, the vehicle should be immediately charged.

- 1) General warning lights.
- 2) Speedometer shows the vehicle's travelling speed in Kilometres per hour (km/h).
- 3) Information display screen show status of vehicle's systems.
- 4) The battery state of charge (SoC) indicators the remaining charger available in the vehicle's battery packs.

5.2 General warning lights (section 1)



WARNING

Failure to act on a dash warning light or indication could result in serious system failure, severe injury, or even death. If in doubt, contact authorised BCI dealer.

	Direction tell-tale, indicators direction of travel.		Direction tell-tale, indicators direction of travel.
	Low beam headlights, when illuminated indicators low beam headlights are on.		When illuminate the charging lead is connected.
	Park / clearance lights, when illuminated indicators lights are on.		High beam, when illuminated the high beam headlights are active.
	Front fog light indicator, when illuminated indicators rear fog light is on.		Rear fog light indicator, when illuminated rear fog light are on.

5.3 Speedometer warning lights (section 2)

INFORMATION			
<i>All warning lights will illuminate for 3 seconds when the ignition key is first turned on. If any light remains or come on, contact an authorised BCI dealer</i>			
	When illuminated the park brake is applied.	EPS	Electric Power Steering warning light, If illuminated indicators fault in the system.
	When illuminated driver's seat belt is not fastened.		ABS fault light, when illuminated contact an authorised BCI dealer.
	When illuminated, indicators low brake fluid.		Vacuum pump warning light. When illuminated indicators fault in the system.
	Tyre pressure alarm.		Brake system fault alarm. When illuminated contact an authorised BCI dealer.

5.4 Information screen (section 3)

FIRE A		Zone A: Displays vehicle status and alerts the driver to any active systems requiring attention. ESC failure and Fire detection warning lights are present here if active.	
HV Battery Voltage&Current: xxxxV xxxxA 12V Battery: xxV Motor Status: STOP/RUN/ERROR Motor Speed: xxxrpm Motor Temp: xxx°C Est.Range: xxxkm B		Zone B: Displays vehicles information. <ul style="list-style-type: none"> • Current battery volts / output amps. • Battery volts of 24volt system. • Status of motor: STOP/RUN/ERROR. • Display motor speed. • Display current motor temperature. • Display estimate range on existing charge. 	
ADAS READY AEBS C		Zone C: Green "READY" indicators ready to drive.	
888888 8888 Km D		Zone D: <ul style="list-style-type: none"> • Displays gear select (P, R, D, N and R). • Displays total kilometres and trip meter. 	
	If EPB illuminated indicates a fault with park brake.		ADAS system failure
	ADAS system shut down		ADAS system active
	AEBS system failure		AEBS system shut down
	AEBS system on		(Flashing) AEBS system active.

Short press **M** button, area **B** display switches between charge and discharge information / fault information, short press the **+**, **-** button on right side and screen switches between accessory information/ battery and system fault information.

5.5 Battery stage of charge indicator (SOC) (section 4).

	When illuminated, 24v battery is at less than 20%. Charging required		Electrical system failure If illuminated.
	Illuminated when the charge station is connected.		Illuminated indicates a door open.
	Airbag system failure If illuminated.		Brake regeneration active If illuminated.
	Motor failure if illuminated.		Battery system failure. If illuminated

6.0 Operation

6.1 Lighting and turning stalk.

Lighting and turning stalk located on the lefthand side of the steering column

	1 Off
	2 Park and clearance lights on
	3 Headlights on
	Indicators. Push level up for right and down for left.
	High Beam. Push forward for on. Pull back to flash.

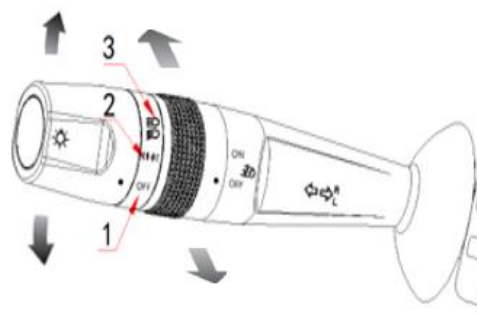

6.2 Wiper and washer stalk.

Wiper and washer stalk located on the righthand side of the steering column.

OFF	Wipers off / pressing button at end of the stalk will active washers.
INT	Intermittent . Raise the stalk one click.
LO	LOW . Raise the stalk two clicks.
Hi	HIGH . Raise the stalk three clicks.

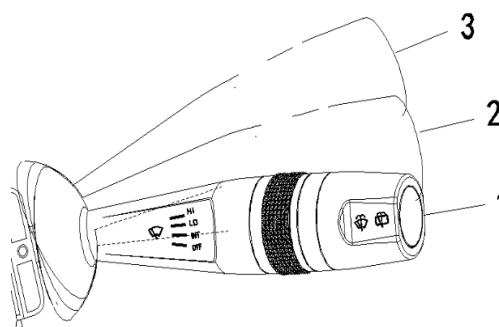

6.3 Central switches

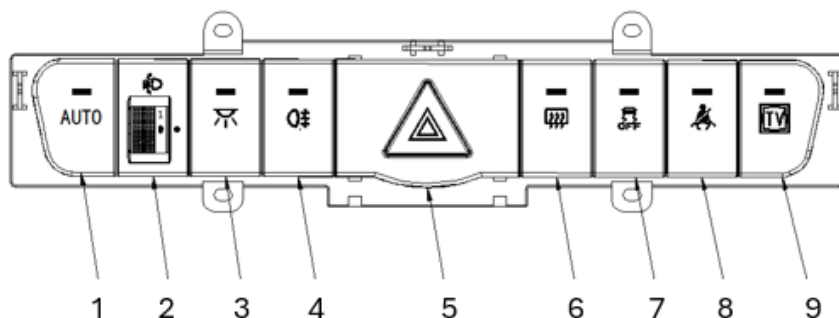

1	Automatic head light switch.	2	Head light height adjustment. 0 = empty load , increase the numbers as weight increases.
3	Rear dome light switch.	4	Rear fog light switch.
5	Hazard light switch.	6	Mirror heating switch.
7	ESC on /off switch.	8	Seat belt switch.
9	TV Switch. Press once to active , and again to deactivate.		

6.4 Driver's seat



WARNING

Don't adjust the driver's seat while the vehicle is moving

Pull up level **(1)** to move the seat forward or rearward.
Release the level to lock into required position.

To raise or lower the seat , push lever **(2)** down repeatedly to lower its height or repeatedly up to raise its height.

To change tilt angle, lean forward slightly and pull up lever **(3)** , the seat back is spring loaded , move the seat to desired position and release the level.



6.5 Gear selector



HAZARD

Do not immediately apply fully acceleration after selecting a gear. This could result in damage to the vehicle. The vehicle must be completely stopped first before changing driving direction.

The gear selector has three positions, "Reverse", "Natural" and "Drive". The selector position will be displayed on the instrument cluster after the ignition of the vehicle is activated.



To select "R" or "D" you must have your foot on the brake pedal first.

6.6 Steering

The vehicle is equipped with an electro-hydraulic power steering system (EHPS). The EHPS activates when the ignition is turned to the START position. On rare occasions, the steering may feel slightly difficult without any warning lights appearing—this is known as a non-failure mode. It can happen when the system experiences excessive steering movements over an extended period, causing it to reach a preset temperature limit and temporarily reduce power assistance. If this occurs, safely stop the vehicle, turn the ignition to ACC or OFF for about 10 minutes to allow the system to cool down, then resume normal driving.

6.7 Braking system



WARNING

If the ABS warning light illuminates on the dashboard, it indicates a fault in the system that should be inspected by an authorised BCI dealer. Failing to address the issue could compromise the vehicle's braking efficiency.

The vehicle is fitted with Anti-lock Braking System which controls the braking pressure under heavy braking to ensure wheels do not lock-up and the driver can maintain manoeuvrability regardless of the situation.

6.8 Park brake (EPB)

The vehicle is fitted with an Electronic Parking Brake (EPB).

The switch to operate this is located on the right side of the dash panel.

Bring the vehicle to a complete stop. Pull the EPB switch, the red LED  will illuminate along with the icon on instrument cluster.

Yellow  icon on dash indicates a fault with the Park Brake circuit.



WARNING

Do not engage the EPB on slopes steeper than 20%, as the vehicle may not hold and could potentially roll away.

6.8.1 Hill Start Assist (HHC)

Hill assist activates when the park brake (EPB) is released, the vehicle is stationary, and steady brake pressure has been applied to the pedal for more than 3 seconds. To disengage, press the accelerator; the brakes will release once the engine torque exceeds the braking force, allowing the vehicle to accelerate.

6.8.2 Emergency Park brake release

This function is used when the brake pedal signal fails and the EPB cannot be released normally. Press the EPB switch and hold for 2 seconds to activate the function.

6.8.3 Emergency braking function.

In the event of a failure in the normal braking system, the EPB can be used as a backup to slow the vehicle. Pull and hold the EPB switch in the applied position until braking is achieved. Releasing the switch or pressing the accelerator will deactivate the emergency braking function.

6.9 Electronic stability system (ESC)

The electronic stability control (ESC) monitors the vehicle's driving characteristics. If the system detects a loss of traction or a significant deviation in direction, it can apply brake pressure and reduce acceleration to help the driver regain control of the vehicle.

The system features an ON/OFF switch (refer to section 6.3, item 7). When the system is OFF, the switch's LED will be illuminated green; when ON, the LED will not be lit. This function is intended for use in situations where slippery or muddy road conditions hinder the vehicle's ability to accelerate from a standstill.



WARNING

Electronic stability control will NOT prevent accidents. Excessive speed in turns, abrupt manoeuvres and hydroplaning on wet surfaces can still result in serious accidents.



INFORMATION

Once the vehicle exceeds 60km/h the system is automatically activated regardless of the switch location

7.0 Air conditioning and heating system



1	Temperature control: Heating clockwise / Cooling anticlockwise. LED screen will display selected temperature.
2	Air conditioner ON/OFF button. LED will illuminate when active.
3	Internal and external air circulation switch. LED screen will display selected mode.
4	Demister mode. Directs air flow onto front windscreen.
5	Air distribution mode. LED screen will display selected direction.
6	Fan speed / decrease.
7	Fan speed / increase.
8	Auto function. When activated, it automatically maintains the temperature displayed on the LED screen.
9	ON/OFF for air conditioning supply to passenger area.
10	Fan speed to passenger area. Clockwise to increase and anticlockwise to decrease.

8.0 Multimedia

Press the TV switch (refer to section 6.3, item 9) to activate. When the TV is on, the switch's LED will illuminate green. Press the switch again to turn off the TV, and the LED will go out.

9.0 Passenger security

9.1 Seatbelt



WARNING

Seatbelts are designed to protect occupants and should always be worn. If a seat belt is not worn or worn incorrectly, it can cause additional injuries, or even death.

Correct seatbelt use.

- Smoothly pull the belt out of the reel.
- Place the belt over your shoulders, running across your chest .
- The lap belt part across your pelvis and hips, buckled low on your hip.
- There should be no twists or slackness in the belt.

9.2 Air bag



WARNING

If the seat position is incorrect or the airbag deployment area is obstructed, the airbag system may not offer the intended protection and could cause additional injuries upon deployment. This poses a risk of injury or even death. To ensure optimal protection, please observe the following guideline

- Keep your distance from the airbags.
- Always grip steering wheel rim. Placing hands at 3 o'clock and 9 o'clock to minimise the risk of injury to hands or arms when airbags deploys.
- Make sure the vehicle occupants keep their head away from deployment areas.
- Make sure passengers are sitting correctly, in other words with feet or legs in the foot well, not resting on the dashboard.
- Don't allow people ,pets or objects between the airbag and passenger.
- Keep the dashboard and windscreen area free, for example do not attach adhesive foils or covers and do not fit brackets to navigation devices or mobile phones.
- Do not attach anything to the airbag covers with adhesive , never cover them or modify them in anyway.
- Do not use the front airbag cover on the front passenger's side as tray.
- Cover, seat covers, cushions or other objects not specifically suitable for seat with integral side airbags, if fitted, must not be used on the front seat.
- Do not hang items of clothing for example coats or jackets over the backrest.
- Do not modify any components of the system or its wiring in anyway. This includes steering wheel, dashboard and seats.
- Do not dismantle the airbag system.



WARNING

Individual components of the airbag system may be hot after deployment. There is danger of injury. Do not touch individual components.

10.0 Charging point

The vehicle charging point is a CCS type 2 plug located within a service hatch between the nearside passenger and sliding doors. Opening the passenger door allows the hatch to be opened. Once the hatch is open the passenger door can be closed.

10.1 Charging



DANGER

*DO NOT touch the terminals within charging point.
Avoid charging in a lightning storm , as a lightning strike may cause damage to equipment or personal injury*

There are two (2) charging methods for this EV cargo van / Bus .

1. **DC** (direct current) charging at dedicated charging stations (max 650V DC , current 100A DC)
2. **AC** (alternating current) charging at dedicated charging stations or home installation (max 220V current 30A AC).



DANGER

Only use chargers that meet Australian standards – Look for this regulatory Compliance Mark.



Charging procedures and times will vary depending on the make and model of charger. The operational requirements for each charger will vary depending on the manufacture so please refer to their instructions for details.

Vehicle connection:

1. Ensure the vehicle is securely parked with park brake applied.
2. Vehicle's ignition is off.
3. Open the charging hatch (section 10.0).
4. Remove dust covers.
5. Remove the CCS 2 lead from its holder and security plug into the vehicle.
6. Refer to the charger manufacturer to start charging process.
7. Once fully charged and charging has stopped , remove CCS 2 and returned to location within the charger.
8. Refit dust covers and close charging hatch.
9. Vehicle is ready to use.



INFORMATION

During the charging process, the Battery Management System (BMS) is active, so it's normal to hear relays clicking and cooling fans running



INFORMATION

Avoid running the vehicle's State of Charge (SOC) in the red zone for extended periods, as this can reduce the battery's lifespan.



DANGER

If charging from home unit, it's recommended that it's via a dedicated supply line, that has been checked and certified by qualified electrician.

10.2 High-voltage (HV) Batteries

The HV batteries have a specific set of parameters when it comes to charging and discharging temperatures. These temperatures directly affect the service life and warranty of the batteries.

1. The charging temperature range is 0-55°C and charging at a higher or lower temperature environment will cause a certain degree of damage and reduced service life of the batteries.
2. The discharge temperature range is: -20-60 °C, however the discharge capacity at lower temperatures (-20-0 °C) may be reduced. The batteries can be used at 45-55 °C ambient temperature, but these higher temperatures will accelerate the aging of the internal material and shorten its service life, so it is not recommended to operate at in these temperatures for long periods.

Battery Precautions:

1. Do not operate an electric vehicle equipped with a HV batteries in an environment where the temperature exceeds 55°C.
2. When the ambient temperature is lower than 0°C, stop charging the battery pack/vehicle.
3. Do not drive in flood waters, where the motors could be submerged.
4. When the vehicle is not driven or stored for long periods of time (over 6 months), the SOC should be at less than 50% and storage environment humidity should be less than 95% RH.
5. If the vehicle is involved in a serious collision that may have impacted the battery pack area, contact Emergency Services and follow their instructions.
6. If the battery packs develop a leak, do not touch. Contact your nearest authorised BCI repairer.



DANGER

If the battery packs have been compromised in anyway seek assistance from the nearest BCI authorised repairer.



DANGER

If there is any leaks in battery area, do not touch coolant, if accidentally touched, quickly wash with large amounts of water. If it comes in contact with eyes, quickly wash and seek medical attention.

11.00 Battery Isolation

There is manual battery isolation switch located on the aisle side of the driver's seat base. Turn the red handle anticlockwise and remove it to disconnect both the low and high voltage circuits.



DANGER

DO NOT touch any ORANGE harness' or cables as they contain High Voltage. Repairs only to be conducted by authorised BCI repairers.

11.1 Flat Batteries

Electric vehicles (EVs) can experience flat 12-volt batteries if auxiliary circuits remain active while the high-voltage circuit is disengaged. It's possible to jump start a vehicle using another vehicles 12-volt battery.



WARNING

Incorrect connections or procedures can cause damage to the vehicle or pose a risk of injury. This work should only be performed by a qualified technician.

Connection:

1. Park the two vehicles as close together as possible.

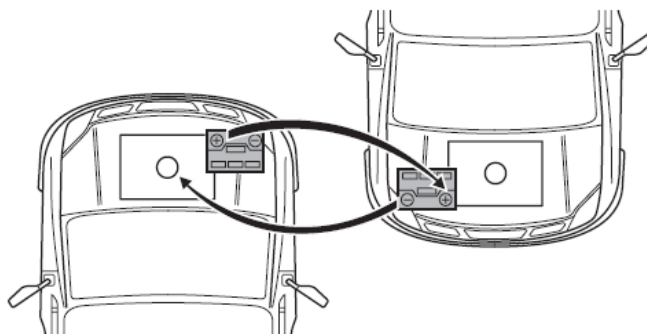

2. Ensure Park brakes are applied on both vehicles.
3. Turn off the motor, engine and all electrical equipment on both vehicles.
4. Connect the positive poles (+) of the two batteries with red jumper lead.
5. Connect the negative pole (-) of the powered vehicle, to a negative earth point of vehicle being charged (Do not connect to the negative post of the battery.)
6. Double check all connections and ensure there are no moving parts on either vehicle at risk of contact.
7. Start or engage the powered vehicle and let it idle for few minutes.
8. Start the vehicle that requires power (section 14.0).
9. The vehicle will now display a green (section 5.4) ready icon.

Disconnect:

1. Turn off the engine / motor on the powered vehicle.
2. Disconnect the jumper cables ensuring that ends don't contact each other or any parts of either vehicle.



HAZARD

DO NOT use any auxiliary systems or electrical appliances of the vehicle being started until jumper cables are disconnected.

12.0 Emergency shutdown Procedure



Warning

In the event of an emergency, bring the vehicle to a stop as soon as it is safe to do so and apply the park brake. Safely evacuate all passengers, ensuring they move to a safe location away from the vehicle and traffic.

Once evacuation is complete, switch OFF ignition and remove key, turn the battery isolation switch to off position and remove the key. Remain at a safe distance and follow company emergency procedures or instructions from emergency services.

1. Turn the main ignition key off and remove key.
2. Locate isolation switch at the base of the operators seat. Turn anticlockwise and remove the key.



13.0 Start/Stop

To initiate.

- Ensure gear selector is in neutral position.
- Turn ignition key to the “ON” position and allow vehicle to carry out self-test (5 seconds).
- Press the brake pedal, turn the ignition key to “START” position and hold for one second, then release.
- “**READY**” will then be illuminated on the dash cluster in green. The vehicle is ready to operate.



WARNING

Ensure all doors are closed and passengers are secured before selecting a direction of travel and moving the vehicle.

To turn off.

- Stop the vehicle in safe location.
- Apply Park brake.
- Turn ignition key from “ON” to “ACC” position. “**READY**” will turn to amber.
- Turn the key to “OFF” and remove key.

14.0 Park assist

When reverse gear is engaged, four radar sensors located on the rear bumper scan for obstacles. If an obstacle is detected, the system calculates the distance and alerts the driver with an audible alarm.

- A single beep sounds when the vehicle is first placed in reverse.
- At 200 cm to 150 cm from the rear of the vehicle, the beeping sounds at 1 Hz.
- At 150 cm to 90 cm, the beeping increase to 2 Hz.
- At 90 cm to 60 cm, the beeping increases to 4 Hz.
- At 60 cm to 40 cm, the beeping increase to 8 Hz.
- At less than 40 cm, the beeping becomes continuous.

14.1 Reverse camera



WARNING

Reversing camera and park assist is to be used as guide only and should not replace observation and personal judgement.

When reverse gear is selected, the main multimedia screen automatically switches to a rearview monitor, displaying the area behind the vehicle for the driver's reference.

15.0 Technical data

15.1 Specifications of the drive motor

Component	Component specifications
Motor model / type	DDM60 / Permanent magnet synchronization
Motor arrangement / location	Longitudinal , centred
Motor cooling method	Water cooled
Dimensions mm	405 x 461
Maximum power	150 kW
Maximum torque	1200 Nm

15.2 Lubricants

Component	Specification	Capacity
Cooling system	HEC-II heavy loading	13 Litres
Rear axle oil	API GL-5 SAE85W/140 (-12~50°C)	4.5 Litres
Brake fluid	DOT 4	2.4 Litres
Power steering fluid	ATF III	3 Litres

Wiper fluid	General purpose / non-freezing point	2 Litres
Refrigerant	R134a	1.6 kgs

15.3 Tyre size / inflation pressures

Model	Tyres		Front		Rear	
	Specifications	Level	kPa	Bar	kPa	Bar
YBL6750EV-RHD	205/75R 16LT	14	740	7.4	740	7.4

15.4 Wheel alignment specifications

Model	Wheel Camber	Toe-in
YBL6750EV-RHD	0°50' ₀ +0°20'	0°08' ₀ +0°05'



HAZARD

Specifications may vary depending on road conditions and local environments. Consult a wheel alignment professional for assistance.

16.0 Towing



WARNING

When towing, ensure compliance with all local regulatory requirements.

Front tow ring:

When towing vehicle from the front, screw the towing ring into the right side of the front bumper. The tow eye is located within the on-board kit, found in front passenger area.

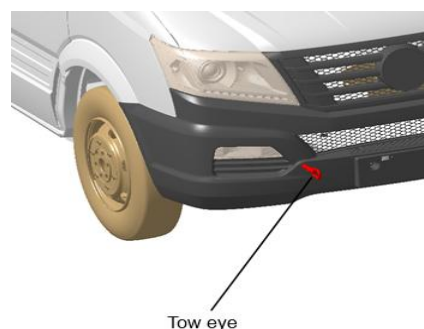

Rear tow ring:

There is a rear tow ring located under the rear step on the passenger side.

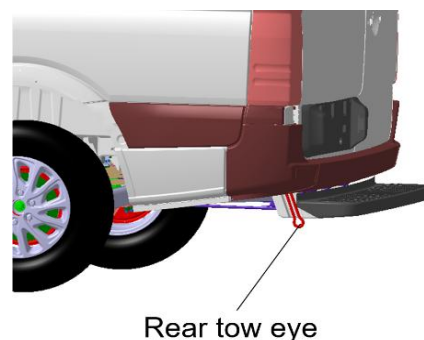

Traction:



HAZARD

If flat towing ensure that the steering can rotate freely, it is important to turn the ignition to the "ON" position. This is to ensure that the steering is unlocked, the turn indicator and the brake lights are working. The gear selector is in "N" position.



WARNING

When the motor is not running, there is no brake booster assist or power steering assist, so more force is required to operate the brakes and turn the steering wheel.

17.0 Spare tyres



WARNING

Ensure the following before changing any tyre:

- *Vehicle is secure in safe location out of all traffic.*
- *Park Brake applied.*
- *Hazard lights are activated, and safety triangles deployed.*
- *All passengers have been disembarked into a safe location.*
- *Vehicle is on flat solid ground that will hold it once jacked.*
- *Wheel chocks are placed under wheels to avoid vehicle run away.*



WARNING

Never position yourself under any part of the vehicle while it is jacked up



WARNING

There are numerous pinch points associated with removing and replacing the spare tyre.

The spare tyre is located inside the spare tyre rack under the rear of the vehicle.

Check the spare tyre regularly to see if it is secure and that the tyre pressure is correct.

The operation of removing the spare tyre is as follows:

1. Open the rear doors.
2. Insert the screwdriver into groove **(2)**, and then pry up the cover **(1)**.
3. Using the lever from the car tool kit, unscrew the exposed bolts counterclockwise about 20 times.

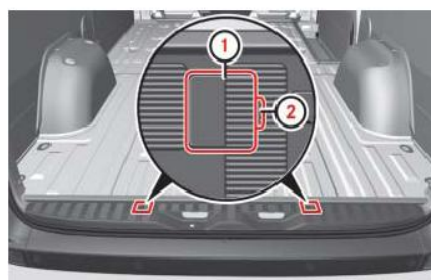

4. Insert the lever into **(4)** on the **(5)** spare tyre rack.
5. Lift the spare tyre rack slightly **(5)** and release the safety latch **(3)**
6. Slowly lower the spare tyre rack on to the **(5)** ground.
7. Carefully remove the spare tyre from the rack.

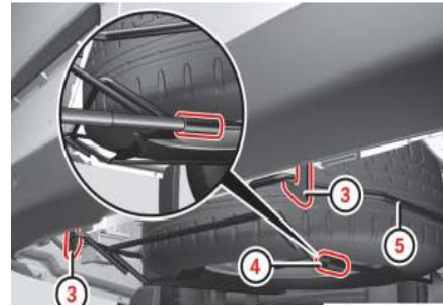

Replacing tyre:

- Place the jack under the vehicle in the specified jacking point. Ensuring its perpendicular to the ground.
- Remove the plastic dress trim from over the wheel nuts.
- Use the supplied socket to loosen all the wheel nuts by turning anticlockwise.
- Jack the vehicle off the ground. Only jack high enough to remove tyre
- Use socket to continue removing all the wheel nuts.
- Carefully remove the wheel and replace with spare wheel.
- Refit wheel nuts and tighten clockwise to 210nm.
- Lower the vehicle back onto the ground and remove jack.
- Re-install dress trim.
- Put away tyre, jacks and vehicle's tools.



INFORMATION

If the tyre is unrepairable and needs to be disposed of, ensure it is done in accordance with local regulatory requirements.